

*emotion of sauna.*



## Assembly instructions and instructions

# 60IR



GB

Made in Germany

CE IP X4

Druck Nr. 29342888en/ -40.07

# English

## Table of Contents

Technical data .....	3
The delivery package includes the following components: .....	3
General Information .....	4
General Safety Precautions .....	4
Assembly of the controller .....	5
Mounting the sensor .....	6
Electrical installations .....	6
Installation of the booth lighting .....	6
Connection example .....	7
Operation .....	8
Error display .....	8
Service Address: .....	9
Guarantee .....	9

## Technical data

Voltage:	230 V N AC 50 Hz
Fusing:	1 x 16 A
Power intake :	max. 3500 W
Control range:	30 - 60° C
Control characteristics:	Digital, two-point control
Sensor system:	KTY sensor with safety temperature limiter 139° C
Heating time limitation	60 Minutes
Ambient temperature:	-10 to 40° C
Protection category:	IP X4
Installation dimensions HxW	120 x 170 mm
Weight:	Approx. 0.7 kg

## The delivery package includes the following components:

- accessory bag, including: 4 tension-plate screws
- an oven-sensor board with overheat shutoff protection, KTY - sensors with sensor housing, two 3x25 mm fastening screws and a 1,7 m long sensor cable.

Dear Customer,

With this IR controller you have purchased a high quality electronic appliance developed and produced in conformance with the latest standards and quality guidelines.

Read these instructions carefully to familiarize yourself quickly and simply with the unit.

## General Information

The IR controller is designed for a voltage of 230 V 50 Hz as a standard feature and requires a separate 16 A fuse.

**Assembly and connection of the infrared equipment and other electric facilities must only be carried out by a qualified specialist; in this regard, VDE 0100 Part 703/2006-2 is to be complied.**

Provide for an all-pole separation device for separation from the line power with a contact opening width of at least 3 mm per pole.

Please read the following installation and operating instructions thoroughly to ensure malfunction-free operation of your IR controller.

## General Safety Precautions

- Ensure that the electrical installation is accomplished only by an authorized electrician.
- Observe the regulations of our electrical power supply company as well as all applicable VDE regulations (DIN VDE 0100).
- Caution! Lethal Hazard: Never attempt to repair or install the unit yourself. Ensure that the housing cover is removed only by a trained employee.
- Use the unit only for the intended purpose for control of IR emitters.
- When installing or working on the system ensure that all poles are separated from the line power, i.e. switch off circuit breakers or main switch.
- Observe safety and installation instructions of the manufacturer.
- This device has not been designed for being used by persons (including children) that are physically or mentally handicapped or have sensory disabilities. Moreover, it is not allowed to use this device without sufficient experience and/or knowledge, unless these persons will be supervised by persons responsible for their security or in case they have been instructed how to use this device.
- Children are to be supervised in order to make sure that they do not play with this device.

## Assembly of the controller



**The control-unit may not be mounted within the IR cab.**

- The controller is pre-installed for the electrical connection.
- The silicon connection cable for the booth lighting is connected in the booth to the booth lighting.
- The connection cable to the infrared emitter is equipped with a plug section that is fed as a lead into the distribution socket. Up to 5 infrared emitters can be connected from there.
- However, ensure that the maximum emission capacity does not exceed 3,5 kW.
- Before the controller can be fastened on the outer wall of the booth, it is necessary to remove the cover on the control unit. For this purpose first pull off the switch toggle, press the retaining lug inward with a flat screwdriver and pull the upper section of the housings up by pivoting.

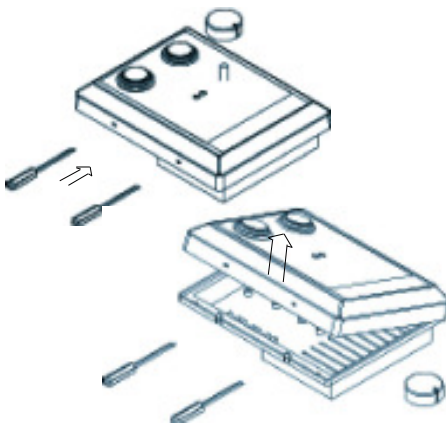

Fig. 1

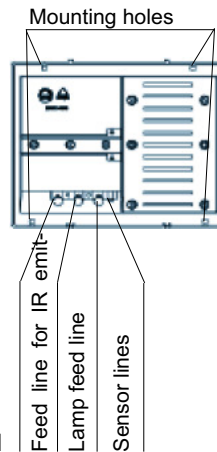

Fig. 2

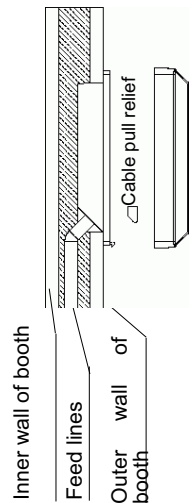

Fig. 3

- The controller is sunk partly in the booth wall. To this end, a right-angled opening of 120 x 170 (height x width) must be inserted in the tongued grooved and beaded timbers. The booth construction should enable a feedthrough for connection and junction cables upwards.
- Now insert the lower part of the appliance into the right-angled opening, after you have fed through the junction and light cables.
- If the sauna booth is not equipped with empty conduit for the connection lines, route the cables visibly on the walls of the booth. In this case cut an additional opening for introducing the lines into the unit at the lower, left corner of the rectangular opening.
- The housing is then secured laterally to the booth wall with the supplied 4 chip-board screws.

- The control unit should be appropriately always fastened to the cab external wall..

## Mounting the sensor

1. Install the sensor in the booth as shown in the figure below.

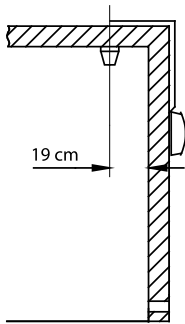

Fig. 4

2. Drill a hole to lead the cable through, preferably through the middle of one of the wooden boards.

3. Route the sensor lines through the drilled hole and connect.

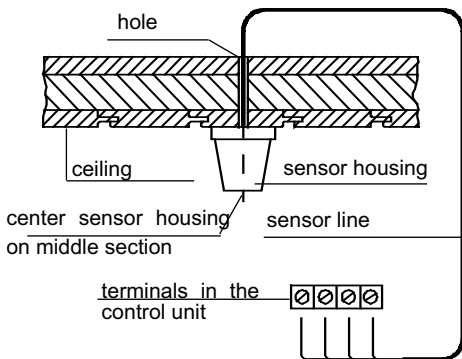

Fig. 5

4. Attach the lines for the limiter (white) and the temperature sensor (red) according to Illust. to the sensor board. Then insert the sensor board into the housing.

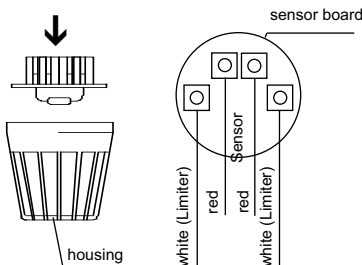



Fig. 6

5. After you are finished installing and have made sure the control unit is functioning properly, check the line for overheat shutoff protection for short circuits. To do this, release one of the white lines in the sensor housing. The control unit's safety relay should now fall, i.e. the heating circuit should now be interrupted.

## Electrical installations

 **The electrical installation may be only carried out by a registered electrical contractor, while adhering to the directives of the local EVU and the VDE.**

## Installation of the booth lighting

- The booth lighting must correspond to the protection type „splash-proof“ and be suitable for an ambient temperature of 125°C.
- The connection cable is to be fed through the hole drilled beforehand, and is to be connected to the booth lighting.
- The booth lighting must always be mounted as far as possible from the positional spot of the infrared emitter, and may not be directly beamed on.

Mount the infrared emitter according to the mounting instructions.

- Unscrew the two screws of the clamped covering for connecting the control cable with the distributor block. Insert the plug into the distributor block and retighten the two screws.

The covering snaps over the circlips and avoids the accidentally disconnection of the joint.

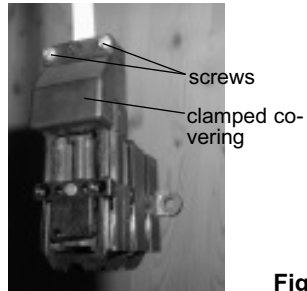
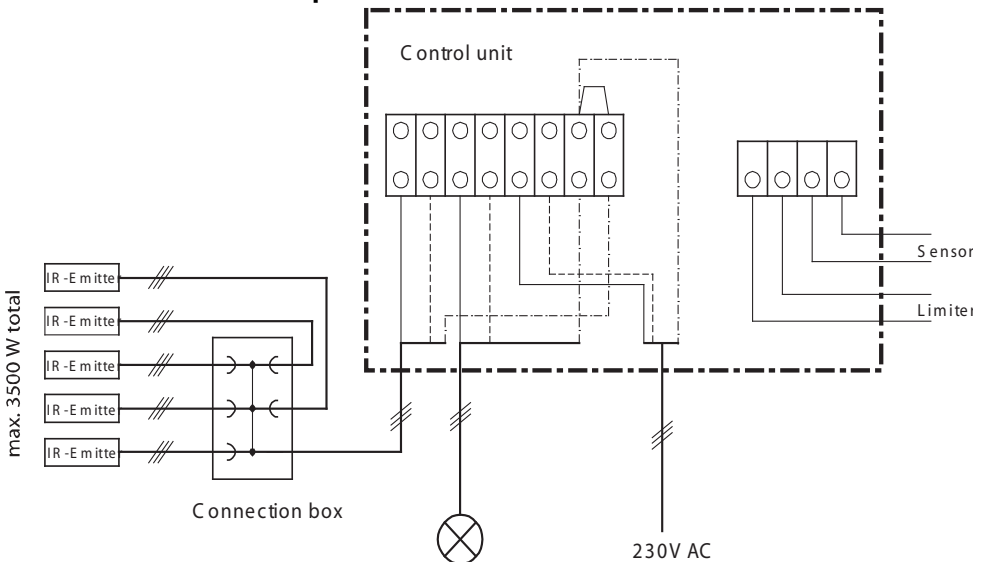

Fig. 7

### Connection example



**Attention!**

**Dear customer,**

according to the valid regulations, the electrical connection of the sauna heater and the control box has to be carried out through the specialist of an authorized electric shop.

We would like to mention to the fact that in case of a warranty claim, you are kindly requested to present a copy of the invoice of the executive electric shop.

## Operation

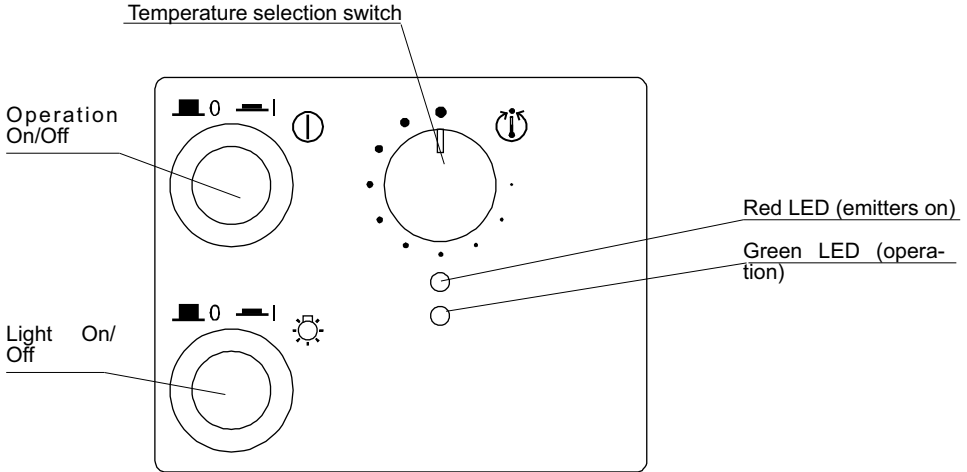

- The IR heat booth can be started up by pressing the top button. The green LED illuminates.
- The system can be switched off by pressing the button again; it is switched off automatically after 60 minutes.
- The booth temperature can be set on the temperature selection knob. The entire control range is from 30 °C to 60 °C.
- Please note that the set temperature applies only for the area surrounding the sensor and that different temperatures can be present in the remaining areas of the booth; particularly areas not reached by the radiation from the IR emitters.
- As soon as the IR emitters begin to heat up, the red indicator LED illuminates.
- Upon reaching the set temperature the IR emitters are switched off and the red indicator LED extinguishes.
- The booth lighting can be switched on and off with the bottom button.

## Error display

Controller does not work: Have fine fuse checked by electrician.

Red LED flashes rapidly: Causes: Sensor and / or limiter defective  
Have sensor and limiter checked by a skilled technician.

Notes for electrician:

The fine fuse in the unit switches at 32 mA T.

The sensor (KTY) has a resistance of approx. 2 kOhm at an ambient temperature of 20 °C.

The limiter switches at 139° C.

Please keep this address in a safe place together with the installation guide.

To help us answer your questions quickly and competently, please provide data printed on the ID plate, to include system type, article no. and serial no., in all inquiries.

### **Service Address:**

EOS-WERKE GÜNTHER GmbH  
Adolf-Weiß-Straße 43  
35759 Driedorf-Mademühlen, Germany  
Fon: +49 (0)2775 82-0  
Fax: +49 (0)2775 82-431  
servicecenter@eos-werke.de  
www.eos-werke.de

## **Guarantee**

The guarantee is taken over according to the legal regulations at present.

### Manufacturer's warranty

- The period of warranty starts from the date of purchase and lasts up to 2 years for commercial use and 3 years for private use.
- Always include the completed warranty certificate when returning equipment.
- The warranty expires for appliances which have been modified without manufacturer's explicit agreement.
- Damages caused by incorrect operation or handling through non-authorized persons are not covered under the terms of warranty.
- In the event of a claim, please indicate the serial number as well as the article code number and type name with expressive description of the fault.
- This warranty covers damaged parts but no defects due to wear and tear.

In case of complaint please return the equipment in its original packaging or other suitable packaging (caution: danger of transport damage) to our service department.

Always include the completed warranty certificate when returning equipment.

Possible shipping costs arising from the transport to and from point of repair cannot be borne by us.

Outside of Germany please contact your specialist dealer in case of warranty claims. Direct warranty processing with our service department is in this case not possible.

Equipment start-up date:

Stamp and signature of the authorized electrician: