

emotion of sauna.



Assembly and Operating Instructions

ECON F1



GB

Made in Germany

CE IP x4

Druck Nr. 29343282en/ -38.07

English

Table of Contents

Delivery Scope	3
General Notices	4
General Safety Regulations	4
Installation of the control unit	5
Electrical installation	6
Operation	7
Button functions	7
Start-up	8
Switching on the unit for the first time	8
Default Parameters	8
Manual Selection of Light Color	8
Automatic Selection of Light Color	8
Effect of Colors	9
Connection Schematic	10
Service Address:	11
Guarantee	11

Technical specifications

Supply voltage:	230 V 1N AC 50 Hz
Fuse protection:	1 x 10 A
Lamp capacity:	400 W max.
Surrounding temperature:	0 to 40° C
Type of protection:	IP X4
Color sequence when in	red - red/yellow - yellow - yellow/green - green - green/
Automatic mode:	blue - blue - blue/red
Color overlap period:	0 seconds
Cycle time:	adjustable from 1 to 10 minutes
Dimensions (H x W x D):	210 x 310 x 80 mm

Delivery Scope

(changes reserved)

The control device consists of:

- Plastic bag with three attachment screws

Dear Customer,

with this coloured light control device, you have purchased a high-quality electronic device, which was designed and produced according to the latest standard and quality guidelines.

With this high-quality coloured light controller, you „operate“ your coloured light device and with the programming options, you will surely quickly find the settings you feel most comfortable with.

Read these instructions carefully so that you will find your way through programming fast and easily.

General Notices

The coloured light control device is intended for 230 V 50 Hz voltage and has to be secured separately with a 10 A fuse.

Only an authorized electrician may install and connect the sauna equipment as well as other electric devices.

The regulations of the Electrician's Association (VDE 0100 / Part 703 / 2006-2) must be observed.

As a rule, sauna equipment may only be connected via a permanent mains connection. This must enable you to separate all poles of the device from the mains with a contact opening width of at least 3 mm.

Read the following installation and operating instructions carefully to ensure the error-free operation of your sauna system.

General Safety Regulations

- Only an authorized electrician may install the electronics.
- The regulations of your power supply company as well as the pertinent regulations of the Electrician's Association (DIN VDE 0100) must be observed.
-  Careful mortal danger! Never perform repairs and installations yourself. Only an expert may remove the casing cover.
- The device may only be operated in accordance with its intended purpose, meaning as a control device for coloured light devices.
- All poles of the device must be separated from the mains prior to all installation and repair work, meaning you have to turn off the fuses and/or main switch.
- Observe the safety and installation notices of the manufacturer.

Installation of the control unit

Before the control unit can be fastened to the outer wall of the cabin, the covering of the control unit must be removed. For this, the two mounting screws (Illust. 1) are loosened. These screws are attached beneath the control panel dials as captive screws, but may be screwed open and closed through the visible holes in the operating panel with a small Phillips screwdriver. After the screws are loosened, the cover is removed.

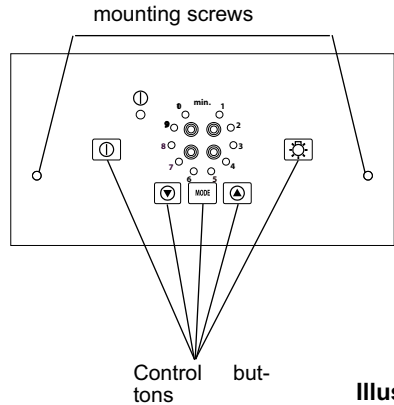

Illust. 1

For practical purposes, the control unit should always be fastened to the outer wall of the cabin near the sauna control unit.

If this is desired, please observe that most sauna cabins have already been equipped with cable conduits for electrical wiring; in this case, the position of the control unit is pre-determined. For the mounting of the control unit, the mounting holes $\text{Æ} 3$ are drilled in accordance with the dimensions given in Illust. 3, and one of the provided wood screws 4 x 20, see Illust. 3.1, is screwed into the wood through the upper middle hole, leaving a 3mm section of the screw projecting out from the wall. The lower part of the control unit is hooked onto this wood screw by its upper mounting hole. Finally all connecting lines - see Illust. 4 - are conducted through the respective feed-through channels into the control unit. The lower part is finally fastened to the cabin wall through the two lower pre-drilled holes.

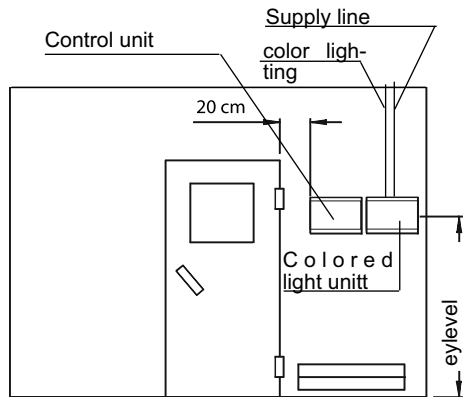

Illust. 2

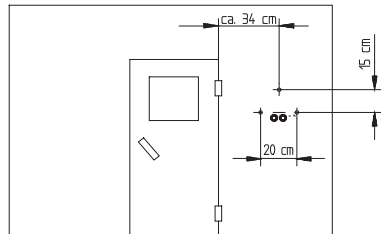

Illust. 3

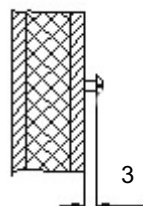

Illust.3.1

Electrical installation

The electrical installation may be undertaken only by an authorized electrician subject to the regulations of the local power utility company and the VDE.

The 3-wire power supply lead is brought to the control unit and connected, as can be seen in Illust. 2. A wiring diagram is posted in the area of the main terminals.

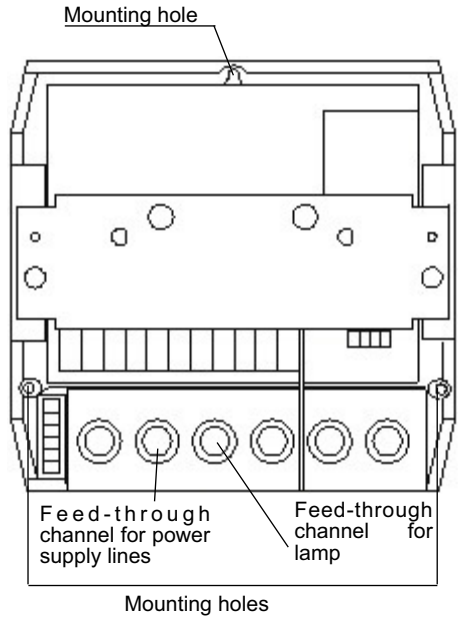





Illust. 4



CAUTION: The colored lights are connected by relay contacts and are not fuse-protected internally. Install a 3 x 1,5 mm² hardwire connection with a fuse protection of 10 A.

Operation

Button functions

-  ON/OFF switch
-  Single color and automatic mode
-  Program button
-  Adjustment buttons

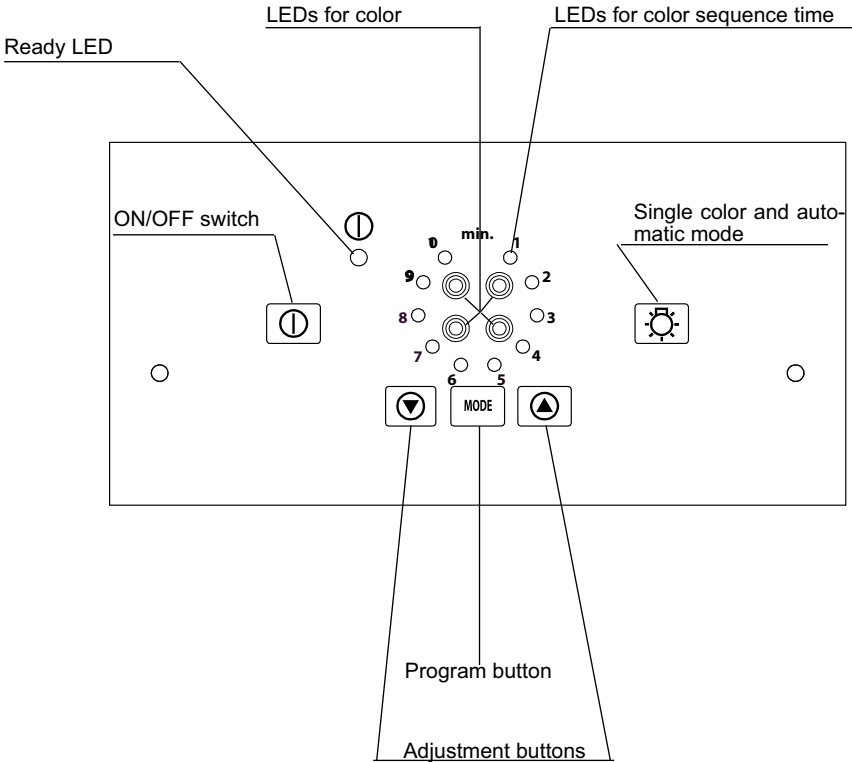

Illust. 6

Start-up

After checking all connections again, connect the unit to the line power by switching on the circuit breakers and/or main switch. The green LED under the **I**-symbol signals that the unit is ready for operation.

Switching on the unit for the first time

Pressing the Start/Stop button **I**, for the first time after connecting the power supply switches the unit to its ready mode. The red LED on the colored light unit and the red LED on the control unit illuminate.

Default Parameters

- Manual colored light selection
- Operating time for individual colors in automatic mode: 5 min.
- Operating time for mixed colors in automatic mode: 10 sec.

Manual Selection of Light Color

It is possible to select between individual colors and mixed colors with the ▼ and ▲ buttons.

Automatic Selection of Light Color

Press the **I** light button to activate automatic selection of the light color.

During automatic operation 5 LED's illuminate for an operating time of 5 minutes.

When the light color selection is switched to automatic the color sequence is red-red/yellow-yellow-yellow/green-green-green/blue-blue-blue/red. In the basic mode the individual colors are held for 5 minutes and the mixed colors for 10 seconds (see „Default Parameters“)

The holding time can be set within the range of 1 min. and 10 min. The row of LED's starts to flash when the „**MODE**“ -button is pressed.

The time can be changed with the ▼ and ▲ buttons.

Pressing the „**MODE**“ -button again confirms the value set and the corresponding number of LED's illuminates in the row of LED's (5 minutes = 5 LED's, 10 minutes = 10 LED's, etc.)

The holding time for mixed colors can be set to 10 seconds (default setting) or to the operating time for the individual colors:

Press the ▼ - and ▲ -buttons simultaneously and hold for 2 seconds until the row of LED's flashes momentarily. Reset by pressing again.

The parameters set last remain set as long as the control is not separated from the line power.

Effect of Colors

The **psychological** influence of the colors is perceived by the eyes. From there the color radiation is transferred to the brain in a complex process, where it develops its effect in the form of certain impressions and energy.

The colors affect the **nervous system** vitalizing the body's resistance. Certain body systems are activated depending on the type of color.

Physical absorption takes place primarily over the skin through direct radiation of the colors.

Chemical absorption takes place in the gastro-intestinal tract in the form of a mixed diet in all colors.

BLUE, the color of the sky and water, is connected with longing, vastness and coolness. Coolness retards human functions, the reason why blue is calming and relaxing and can help alleviate nervous disorders, insomnia, restlessness and fear.

GREEN is the color of nature. Green light soothes and inspires simultaneously. It provides relaxation and regeneration. Green light is reputed to have a positive effect on the bronchi and lungs and to be helpful for nervous disorders, headache and inflammation of the joints.

YELLOW is said to intensify a positive vital attitude and increase general well-being. Yellow colors can stimulate and fortify the nerves and dispel gloom and melancholy, gastro-intestinal disorders can be compensated.

RED is associated with fire and blood. The color for activity, vitality and warmth. Red is reputed to stimulate circulation and therefore contribute to a general increase in well-being and vitality

Connection Schematic

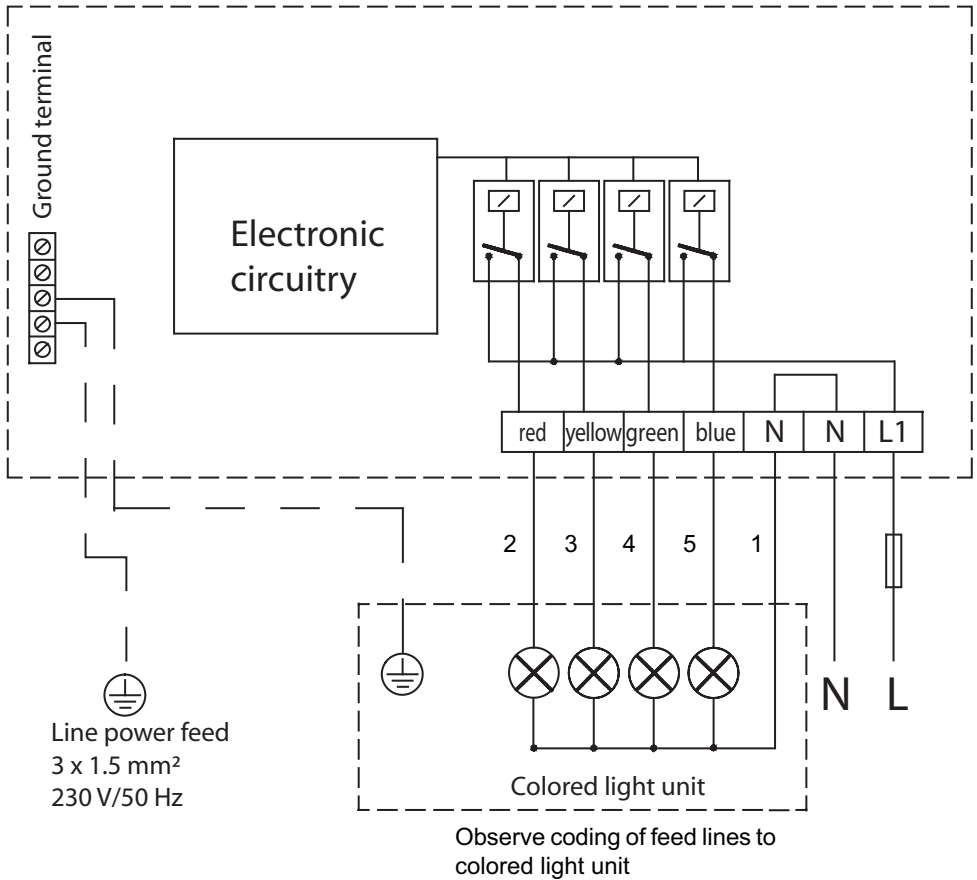

Illust. 7

Wiring codes:

green/yellow	= PE
1	= N
2	= red
3	= yellow
4	= green
5	= blue

Attention!

Dear customer,

according to the valid regulations, the electrical connection of the sauna heater and the control box has to be carried out through the specialist of an authorized electric shop.

We would like to mention to the fact that in case of a warranty claim, you are kindly requested to present a copy of the invoice of the executive electric shop.

Please keep this address in a safe place together with the installation guide.

To help us answer your questions quickly and competently, please provide data printed on the ID plate, to include system type, article no. and serial no., in all inquiries.

Service Address:

EOS-WERKE GÜNTHER GmbH
Adolf-Weiß-Straße 43
35759 Driedorf-Mademühlen, Germany
Fon: +49 (0)2775 82-0
Fax: +49 (0)2775 82-431
servicecenter@eos-werke.de
www.eos-werke.de

Guarantee

The guarantee is taken over according to the legal regulations at present.

Manufacturer's warranty

- The period of warranty starts from the date of purchase and lasts up to 2 years for commercial use and 3 years for private use.
- Always include the completed warranty certificate when returning equipment.
- The warranty expires for appliances which have been modified without manufacturer's explicit agreement.
- Damages caused by incorrect operation or handling through non-authorized persons are not covered under the terms of warranty.
- In the event of a claim, please indicate the serial number as well as the article code number and type name with expressive description of the fault.
- This warranty covers damaged parts but no defects due to wear and tear.

In case of complaint please return the equipment in its original packaging or other suitable packaging (caution: danger of transport damage) to our service department.

Always include the completed warranty certificate when returning equipment.

Possible shipping costs arising from the transport to and from point of repair cannot be borne by us.

Outside of Germany please contact your specialist dealer in case of warranty claims. Direct warranty processing with our service department is in this case not possible.

Equipment start-up date:

Stamp and signature of the authorized electrician: