

emotion of sauna.



Installation and User's Guide

FL 2000 K / FL 2001 K



GB

CE  IP x4

Druck-Nr. 29342615en /23.08

English

Table of Contents

Important Notes	2
Installation.....	3
Installation inside the cabin unit	3
Installation on the wall / in the ceiling.....	3
Installation on the cabin wall	4
Start-up	5
Replacing lamps and starters	5
Performance data	5
Service Address:.....	8
Guarantee	8
Handling procedures for return shipments (RMA) - Details for all returns !.....	9

Important Notes



Improperly installed hardware can present a fire hazard! Please read this installation guide thoroughly. It is especially important to consider applicable dimensions and observe the following instructions:

- The colored light unit is designed for a supply voltage of N 230 V AC via colored light control unit.
- Only an expert may install and connect the colored light unit, control unit and other electrical equipment. In this respect it is especially important to meet the required safety precautions by VDE 0100 v. § 49 DA/6 and VDE 0100 Part 703/2006-2 § 4.
- The control unit EMOTEC C55, ECON F1 or 60FL is must be used to control the colored light unit. Affix this control unit in an appropriate location to the outside wall of the cabin.



WARNING! Never mount the unit directly over the oven in the cabin ceiling or on the cabin wall.

- The unit is equipped with a safety glass panel. Never operate the unit with a broken safety glass panel.
- Only a locally certified electrician may hard-wire the sauna system (sauna oven, control unit, lighting, etc) to the power supply. All connecting lines laid on the inside of the sauna cabin must be able to withstand a surrounding temperature of at least 140°C. Silicone lines are recommended for practical purposes.
- **WARNING:** Do not cover rear side of unit with insulating material (rock wool, etc.) so as not to create an accumulation of heat.

Installation

Installation inside the cabin unit

To facilitate this, it is necessary to cut a rectangular opening of 670 x 280 mm into the ceiling of the cabin for the small colored light unit (FL 2000 K) as in Illust. 1. For the larger colored light unit (FL 2001 K) you will need an opening of 1280 x 280 mm.

The installation inside the cabin unit must not be carried out in the area 1 of the cabin (illustr. 2)!

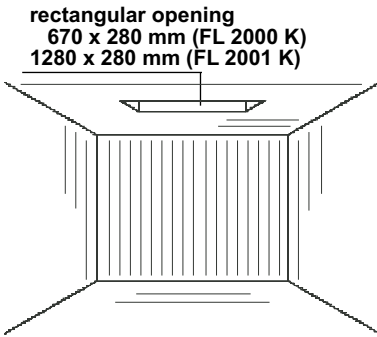

Illust. 1

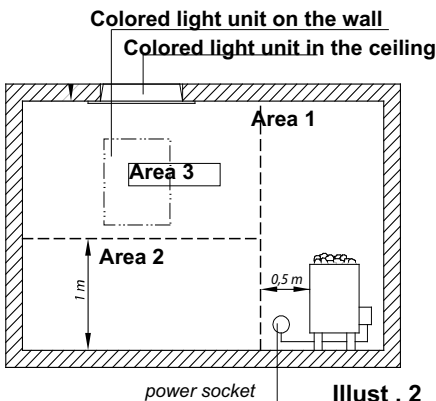

Illust. 2

Installation on the wall / in the ceiling

Attention: For installation of the colored light unit in the wooden profiles of the cabin, please remove the lateral wooden covers.

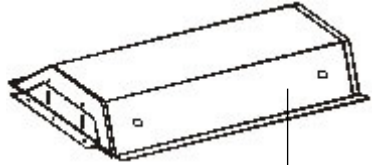

lateral wooden cover

Illust. 3

Release the quick release fastener screws (illustr. 4) and open the stillage.



Illust. 4

Insert the unit bottom-up into the rectangular opening and fix the unit at the lateral angle brackets with each two wooden screws 4 x 25 (illustr. 5 to 8).

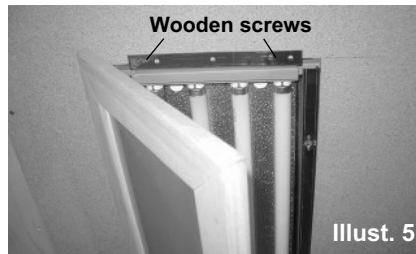

Illust. 5

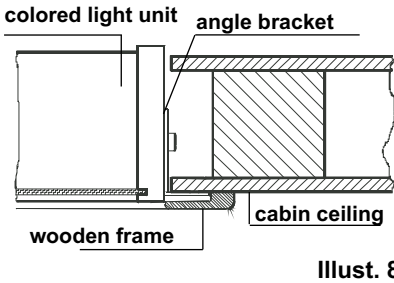
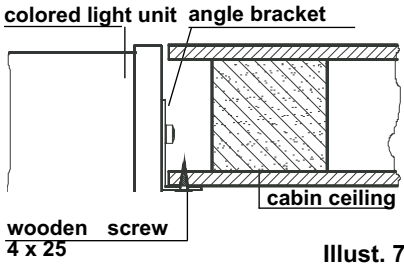
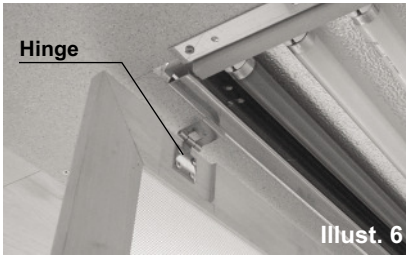

Shut the stillage afterwards and tighten the quick release fastener screws (illust9).

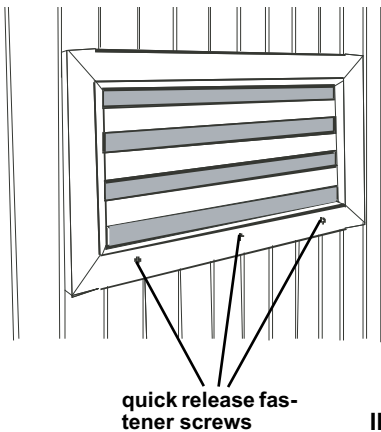

Installation on the cabin wall

You may only install the unit on the cabin wall in areas 2 and 3 inside the cabin (Illust. 10).

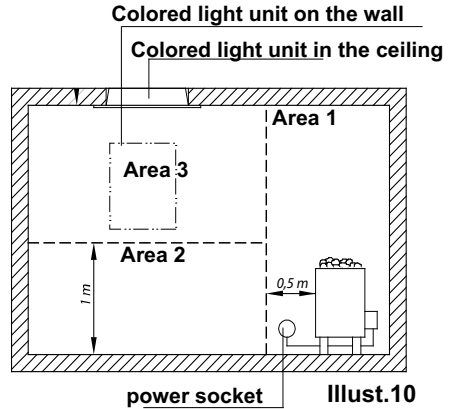

To accomplish this, remove the angle brackets on each side (Illust. 11), since they are not needed for installation on the cabin wall.

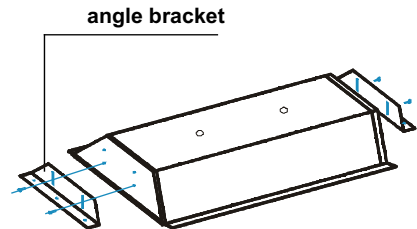

Illust . 11

Mount the two included mounting brackets on the wall, leaving a horizontal distance of 500 mm (for type FL 2000 K) or 1110 mm (for type FL 2001 K) respectively between them (Illust. 12)

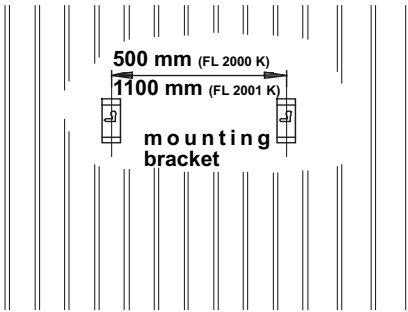

Illust. 12

Unscrew the mounting screws on the rear side of the unit somewhat, so as to create a 4 mm gap between housing and the screw head (Illust. 13).

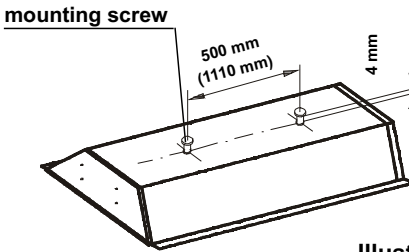

Illust. 13

Now insert the unit with the mounting screws into the holes in the mounting brackets and snap it into place by pushing it sideways. Fasten the unit with the two wooden strips (Illust. 14).

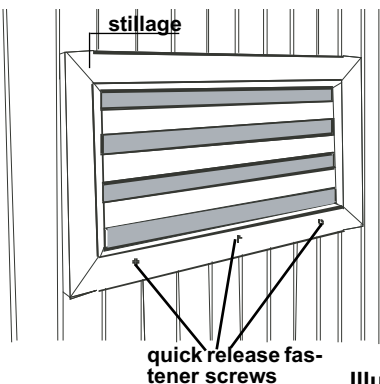

Illust. 14

Start-up

Start operation of the colored light unit with the control unit, type EMOTEC C55, ECON F1 or 60FL. To accomplish this, refer to the manual of the control unit.

Replacing lamps and starters

WARNING! Use only original manufacturer's replacement parts.

Release the quick release fastener screws and open the stillage.

Now you can change the lamps and/or the starters. The lamps and starters can be removed by unscrewing them from their sockets.

Now insert the new lamps or starters into the sockets and turn them about 90 degrees.

Shut the stillage afterwards and tighten the quick release fastener screws

Performance data

FL 2000 K
 4 special-purpose fluorescent lights,
 18 W each
 voltage: 230 V AC N 50 Hz
 power consumption: 80 W

FL 2001 K
 4 special-purpose fluorescent lights,
 36 W each
 voltage: 230 V AC N 50 Hz
 power consumption: 160 W

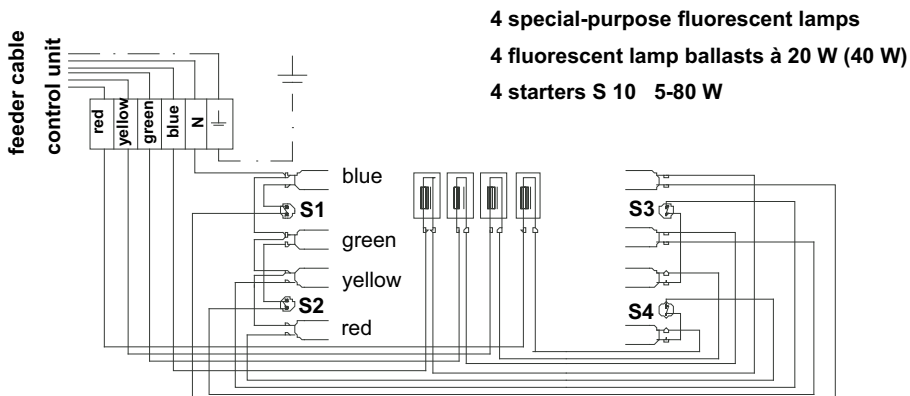

Connect the control unit according to the wiring diagram below.

color coding:

- | | |
|--------------|----------|
| green/yellow | = PE |
| 1 | = N |
| 2 | = red |
| 3 | = yellow |
| 4 | = green |
| 5 | = blue |

Wirkungsweise der Farben

Die **seelische** Beeinflussung durch die Farben erfolgt über die Augen. Von dort wird die Farbstrahlung aufgrund komplexer Vorgänge weiter ins Gehirn geleitet und entfaltet dort ihre Wirkung in Form von bestimmten Vorstellungen und Energien.

Die **nervliche** Farbaufnahme führt zu einer Belebung der Körperabwehr. Je nach Farbart werden bestimmte Körpersysteme angesprochen und aktiviert.

Die **physikalische** Aufnahme geschieht im wesentlichen über die Haut durch direkte Farbstrahlung.

Die **chemische** Aufnahme erfolgt im Magen/Darmtrakt in Form von Mischkost in allen Farben.

BLAU, die Farbe des Himmels und des Wassers, verbindet man mit Sehnsucht, Weite und Kälte. Kälte verlangsamt die menschlichen Funktionen, der Grund, warum Blau beruhigend und entspannend wirken soll und bei nervösen Störungen, Schlaflosigkeit, Unruhe und Angstzuständen helfen kann.

GRÜN ist die Farbe der Natur. Grünlich besänftigt und inspiriert zugleich. Es schenkt Erholung und Regeneration. Grünlicht soll Bronchien und Lunge positiv beeinflussen können und bei Nervenleiden, Kopfschmerzen und Gelenkentzündungen hilfreich sein.

GELB soll die positive Lebenseinstellung und das allgemeine Wohlbefinden steigern. Gelbe Farben können die Nerven anregen und stärken sowie Trübsinn und Melancholie vertreiben, Magen- und Darmstörungen können ausgeglichen werden.

ROT assoziiert man mit Feuer und Blut. Die Farbe der Aktivität, Vitalität und Wärme. Rot soll die Durchblutung anregen und somit zu einer allgemeinen Steigerung des Wohlbefindens und der Vitalität beitragen.

Please keep this address in a safe place together with the installation guide.

To help us answer your questions quickly and competently, please provide data printed on the ID plate, to include system type, article no. and serial no., in all inquiries.

Service Address:

EOS-WERKE GÜNTHER GmbH
Adolf-Weiß-Straße 43
35759 Driedorf-Mademühlen, Germany
Fon: +49 (0)2775 82-0
Fax: +49 (0)2775 82-431
servicecenter@eos-werke.de
www.eos-werke.de

Guarantee

The guarantee is taken over according to the legal regulations at present.

Manufacturer's warranty

- The period of warranty starts from the date of purchase and lasts up to 2 years for commercial use and 3 years for private use.
- Always include the completed warranty certificate when returning equipment.
- The warranty expires for appliances which have been modified without manufacturer's explicit agreement.
- Damages caused by incorrect operation or handling through non-authorized persons are not covered under the terms of warranty.
- In the event of a claim, please indicate the serial number as well as the article code number and type name with expressive description of the fault.
- This warranty covers damaged parts but no defects due to wear and tear.

In case of complaint please return the equipment in its original packaging or other suitable packaging (caution: danger of transport damage) to our service department.

Always include the completed warranty certificate when returning equipment.

Possible shipping costs arising from the transport to and from point of repair cannot be borne by us.

Outside of Germany please contact your specialist dealer in case of warranty claims. Direct warranty processing with our service department is in this case not possible.

Equipment start-up date:

Stamp and signature of the authorized electrician:

Handling procedures for return shipments (RMA) - Details for all returns !

Dear customer

we hope that you will rejoice in the ordered articles. Just in case that you are not entirely contented as an exception, please follow the procedures specified below. This enabling us to ensure a quick and smooth handling of the return shipment.

Please absolutely respect for all returns!

- Please add the available **RMA-voucher** always **completely filled out** together with an **invoice copy** to the return shipment! Do not stick it on the goods or on the packaging. **We do not accept the return shipment without these papers.**
- Not prepaid parcels **will be refused** and returned to Sender! Please always ask for the **RMA-No.** for the cheapest return.
- **Please pay attention that** the goods have to be sent back **without visible marks of use** in the **original scope of delivery and in original packing.**
- We recommend to use an **additional solid and break-proof covering box** which should be padded out with styrofoam, paper or similar. Transport damages as a result of faulty packing are for the sender's account.

Form of complaint:

1) Transport damage

- Please check the content of your parcel immediately and advise the forwarding company of a claim (parcel service/ freight forwarder)
- Do not use damaged goods!
- Ask the forwarder **for a written acknowledgement of the damages.**
- **Report the claim promptly by phone to your dealer.** He will discuss with you how to act in this case.
- If the transport box has been damaged, please use an additional covering box. Do not forget to add the **acknowledgement of the damage of the forwarding company !**

2) Faulty goods

- The implied warranty period is 2 years. Please contact your dealer in case of **faulty or wrong articles or missing accessories.** He will discuss with you the individual case and try for immediate and customer-friendly solution.
- For **economic returns** within Germany you will get an **RMA-number from the manufacturer.**
- All returns have to be in the **original packing of the goods with corresponding accessories.** Please repack the goods to avoid damages. In case of wrong delivery, please do not use this article !

3) Problems of installation and functioning

- Please **read the manual carefully first of all** and pay attention to the indicated assembly or installing instructions.
- **Your dealer should be the first contact person** because he knows his products best and also knows possible problems.
- **In case of function problems with an article,** please check at first whether there is an obvious material defect. The quality system in our factory reduces malfunctions of new appliances to almost zero.