

emotion of sauna.



ECON 4509



GB Assembly and operating instruction

Made in Germany

CE IP x4

Druck Nr. 29343999en/ - 44.09

English

Table of Contents

General information concerning sauna bathing	3
General safety precautions	4
Installation of the control units	5
Electrical installation	7
Installation of the cabin lighting	8
Sensor installation	8
Startup	8
Fuse protection of the sauna lighting	9
Safety cutoff	9
Wiring diagram	10
Service Address:	11
Guarantee	11
Handling procedures for return shipments (RMA) - Details for all returns !	12

General information concerning sauna bathing

Dear customer,

with purchase of this sauna control unit you opted for a superior quality, high-tech electronic device which was developed and manufactured according to the highest standards and guidelines.

Please note that an optimal interaction of sauna cabin, sauna oven and sauna control unit is mandatory for a pleasant sauna climate in your cabin.

With this superior sauna control unit you can „operate“ your sauna system, and thanks to the many individual programming settings you will surely soon find the setting that suits you best.

Perception in the sauna is very subjective, therefore it really requires your own perception, or that of your family to find the most suitable settings.

By default the finnish sauna is preset to 95°C. For steam operation the values are set to 60°C and 60% humidity.

The following operation instructions describe how to pre-select „your“ climate in the cabin. Read these instructions carefully, so that you quickly and easily find your way through the programming process.

Please note the variation in temperatures in the cabin while sauna bathing. The hottest area is directly under the cabin ceiling, whereas there is a steady temperature gradient towards the floor of the cabin. Inversely, the relative humidity is lowest directly under the cabin ceiling and the highest on the cabin floor.

For safety reasons the temperature sensor with the overheat safety shutdown is located on the cabin ceiling above the oven, since this is the hottest area in the cabin.

Therefore there will always be temperature variations between the temperature sensor of the control unit and the thermometer in the cabin.

For the cabin light use only light bulbs. Do not use fluorescent lamps, energy saving lamps and gas discharge lamps.

For example, when pre-setting the cabin temperature to 100°C, the thermometer inside the cabin may easily show 85°C - 90°C. This complies with the typical climate inside the cabin.

Always observe hygiene. Always use hand- or bathing towels, to avoid getting perspiration on the wood.

To protect your cabin from possible damages due to steam operation, we recommend reheating or drying the cabin after every steam bath.



In addition, a fan can help to dissipate used humid air in badly ventilated areas.

To avoid the perception of draft, you should avoid using any ventilation system while sauna bathing. It should only be used if recommended by the cabin manufacturer



Always make sure no objects are located on the sauna oven before starting the heating cycle.

General safety precautions

- his device has not been designed for being used by persons (including children) that are physically or mentally handicapped or have sensory disabilities. Moreover, it is not allowed to use this device without sufficient experience and/or knowledge, unless these persons will be supervised by persons responsible for their security or in case they have been instructed how to use this device.
- Children are to be supervised in order to make sure that they do not play with this device.
-  Attention: It is forbidden to install the control box in a closed switch cabinet or behind a wooden panelling!
- The electrical installation may be done only by a qualified electrical technician.
- You must comply with the regulations of your power supply company and applicable VDE regulations (DIN VDE 0100).
-  WARNING: Never attempt repairs or installations yourself, as this could result in serious injury or death. Only a qualified technician may remove the housing cover.
- Please note the dimensions in the assembly instructions, especially when installing the temperature sensor. The temperature above the oven is critical for the temperature setting. The temperature can be held within operating parameters and a minimal temperature gradient inside the bench area of the sauna cabin can be achieved only if unit is assembled correctly.
- The device may only be used as intended as a control unit for sauna ovens up to 9 kW. (Up to 36 kW when combined with a breaking capacitor).
- Completely disconnect the control unit from the electrical circuit, i.e. flip all circuit breakers or the main circuit breaker during each installation or repair.
- Please note the safety and installation information from the sauna oven manufacturer.
- Always heed the specifications and instructions of the cabin manufacturer, too.



Attention!

Dear customer,

according to the valid regulations, the electrical connection of the sauna heater and the control box has to be carried out through the specialist of an authorized electric shop

We would like to mention to the fact that in case of a warranty claim, you are kindly requested to present a copy of the invoice of the executive electric shop.

Installation of the control units

Before the control unit can be fastened to the outer wall of the cabin, the covering of the control unit must be removed. For this, the dials are pulled from their spindles with a slight tug, and the two mounting screws (Illust. 1) are loosened.

These screws are attached beneath the control panel dials as captive screws, but may be screwed open and closed through the visible holes in the operating panel with a small Phillips screwdriver. After the screws are loosened, the cover is removed.

For practical purposes, the control unit should always be fastened to the outer wall of the cabin, to which the sauna oven inside the cabin is also attached.

The sensorlines (capillary tubes) which as explained later need to be mounted in the sauna cabin above the sauna oven, are roughly 120 cm long.

These capillary tubes cannot be elongated.

Please observe that most sauna cabins have already been equipped with cable conduits for electrical wiring. In this case, the position of the control unit is pre-determined.

For the mounting of the control unit, the mounting holes $\varnothing 3$ are drilled in accordance with the dimensions given in Illust. 3, and one of the provided wood screws 4 x 20, see Illust. 3.1, is screwed into the wood through the upper middle hole, leaving a 3mm section of the screw projecting out from the wall. The lower part of the control unit is hooked onto this wood screw by its upper mounting hole. Finally all connecting lines-see Illust. 4-are conducted through the respective feed-through conduits into the control unit. The lower part is finally fastened to the cabin wall through the two lower pre-drilled holes.

If the sauna cabin is not equipped with cable conduits for the connecting lines, these lines must be laid directly onto the cabin wall, where they will be visible. For this purpose,

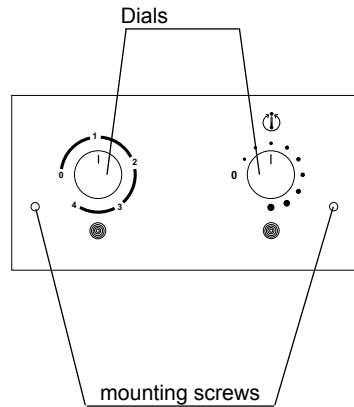

Illust. 1

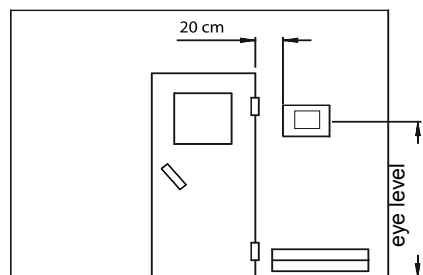

Illust. 2

the three mounting holes must be pre-drilled, as shown in Illust. 3. Finally, align the lower part of the control unit over the drilled holes and sketch the right-hand feed-through hole for the sensor lines onto the cabin wall. Drill a roughly 10 mm feed-through hole at this spot.

At delivery, the capillary tube sensors may be found in the control unit. Unroll the sensors carefully and pull them through the afore drilled hole into the cabin. The capillary tubes must not be bent or damaged. The smallest bending radius should not be less than 3-4 cm during and after installation. Pull the capillary tubes completely into the cabin. No excessive length should be in the control unit.

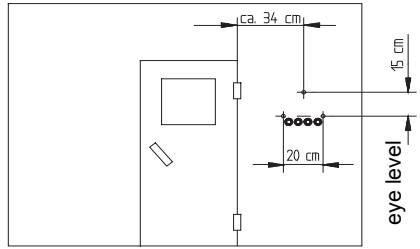

Illust. 3

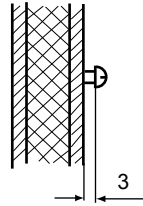

Illust. 3.1

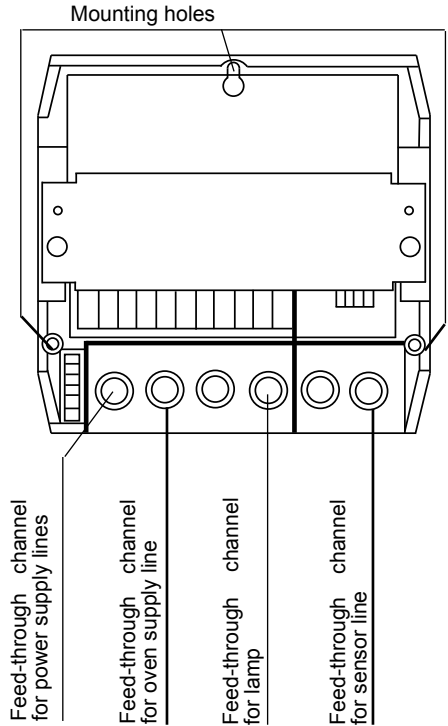

Illust. 4

Electrical installation

The electrical installation may be undertaken only by an authorized electrician subject to the regulations of the local power utility company and the VDE.

The 5-wire power supply lead is brought to the control unit and connected, as can be seen from Illust. 5. A wiring diagram is posted in the area of the main terminal. Install the sauna oven according to the installation guide in front of the air intake vent, and drill a roughly 10 mm hole beside the air intake vent.

Lead the oven connecting cable through this hole to the outside, install a distribution box near the air intake vent which is suitable for use in wet areas, lay a 5-wire power supply lead between distribution box and control unit, connect in the distribution box with the silicon connecting line in accordance with the wiring diagram. The minimum diameter of the connecting line is shown in the chart below.

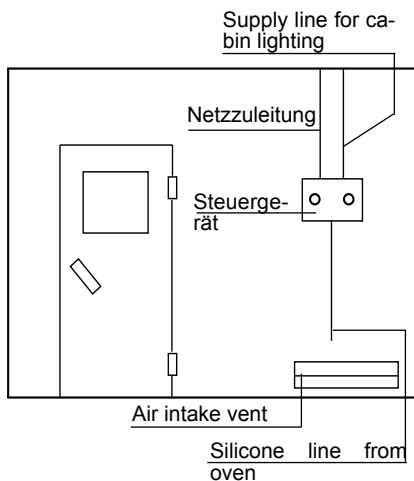

Illust.5

Capacity acc. DIN	Electrical Connection	Fuse control unit in A	Temperature regulation range	Installation dimensions H/W/D cm	For cabin size	Connecting cable main - control unit in mm ²	Connecting cable control unit - heater in mm ²
4,5 kW	3N AC 50 Hz 400 V	3 x 16	40 - 115° C	24 / 31 / 8	4 - 6	5 x 2,5	5 x 1,5
6,0 kW					6 - 10		
7,5 kW					8 - 12		
9,0 kW					10 - 14		

All cross sections of a line are minimum diameters in mm² (Copper line)

When connecting the sauna system, a device which allows the unit to be disconnected from the power source with a contact distance of at least 3 mm from all terminals must be provided. LS switches, fuses and relays are considered suitable devices for disconnecting the unit.

Installation of the cabin lighting

All electrical installations in the sauna cabin must be able to withstand surrounding temperatures of at least 140° C. The connecting cable must be led through the previously drilled hole and connecting in the control unit in accordance with the circuit diagram.

The sauna lamp must always be mounted as far as possible from site of installation of the sauna oven. To this end, the sauna wall opposite the oven or the adjacent corners may be chosen.

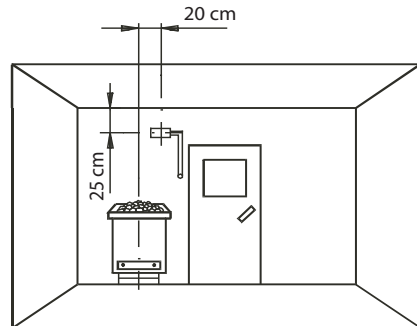

Illust.6

Sensor installation

The thermostatic control unit is equipped with a thermostat and an overheat safety shutdown device. Pull the capillary tube sensors through the afore drilled hole into the cabin and affix them in the retainer slots of the sensor retainer provided. The capillary lines must not be bent or damaged. The smallest bending radius should not be under 3-4 cm.

Use the provided wood screws to center the sensor mount over the free air exhaust vents of the oven which face the cabin door, 25 cm below the cabin ceiling on the cabin wall in accordance with Illust. 6.

The previously described position must be observed in any case; otherwise, the target temperatures will not be reached. The capillary tube lines can be mounted to the cabin wall with the mounting screws provided.

temperatures will not be reached. The capillary tube lines can be mounted to the cabin wall with the mounting screws provided.

The excess length of the capillary tube sensors should be rolled up and must be placed into the cabin. Don't push back the sensors into the control unit under any circumstances.

Startup

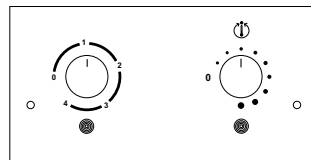

Illust.7

Operation of the sauna system is started with the left-hand timer switch. The maximum activation time is 4 hours due to safety precautions. During this time the green signal lamp lights up. After 4 hours the sauna oven and the cabin light will shut itself down. The cabin temperature is pre-selected with the right-hand thermostat dial. The total control range is between ca. 40 and 115° C. As soon as the sauna oven reaches heat mode, the red signal lamp for „Heating“ lights up. When the desired sauna temperature is reached, the heat mode will be stopped (the signal lamp goes out).

Fuse protection of the sauna lighting

These tasks may only be accomplished by a expert!

The sauna lighting and the control circuit are protected by a microfuse in the control unit. To replace the fuse, the system must be disconnected from the power source, as with all tasks on the control unit.

After you have become familiar with the function of the control unit through this text, we wish you many relaxing hours in your sauna!

Note

Is there a problem reaching the required bathing temperature, or is the temperature different from that indicated on the thermometer in the cabin?

Please note that the temperature sensor is positioned in the area of the heating system. The thermometer is always located in a different place (for ex. on the back wall of the cabin over the recliner bench). The sensor, however, can only measure the temperature in its immediate vicinity; even differences of only 25 cm between sensor and thermometer can lead to temperature differences of up to 15° C. In addition, many bimetallic strip thermometers react very sluggishly, so that the actual temperature is sometimes displayed only after about one hour. The thermometer should not be installed with the complete housing surface flush with the cabin wall but rather with some clearance in relation to the wall. This way you will reduce the reaction time.

It is therefore entirely possible that your thermometer will show a lower value than the one you have set at the control unit.

Safety cutoff

The sauna control unit is equipped with a temperature limiter for security.

In case of a malfunction this temperature limiter cuts off all 3 phases by safety reasons.

Once the temperature limiter has cut off the current, he must be reset mechanically.



Attention:

Cut off the control unit from the mains at first.

Open the control unit.

There are 3 control elements visible now. In the middle is the temperature limiter for security.



Abb. 8

Press the 3 locking pins behind the connecting plug until you feel a switching point.

Close the control unit again before setting-up operation.

In case the temperature limiter should cut off again immediately after taking into operation, the unit has to be checked by a specialist.

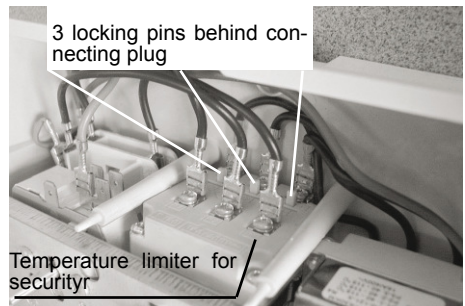
Wiring diagram

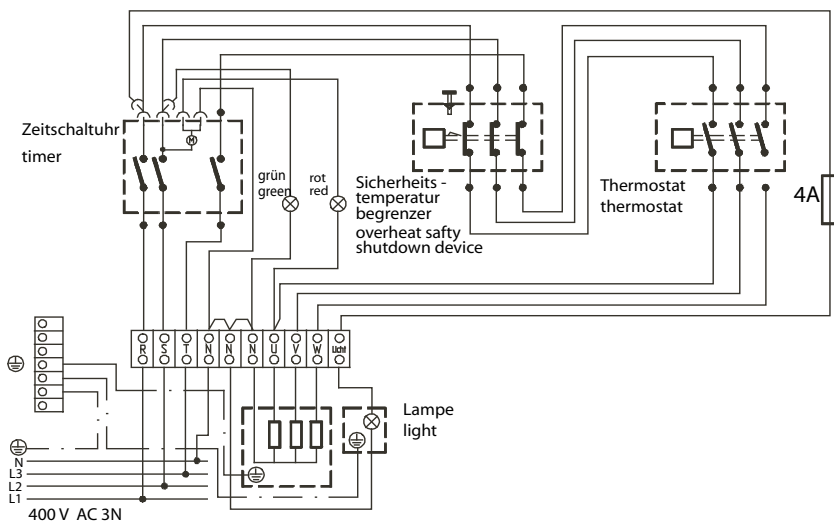

Please keep this address in a safe place together with the installation guide.

To help us answer your questions quickly and competently, please provide data printed on the ID plate, to include system type, article no. and serial no., in all inquiries.

Service Address:

EOS-WERKE GÜNTHER GmbH
Adolf-Weiß-Straße 43
35759 Driedorf-Mademühlen, Germany
Fon: +49 (0)2775 82-0
Fax: +49 (0)2775 82-431
servicecenter@eos-werke.de
www.eos-werke.de

Guarantee

The guarantee is taken over according to the legal regulations at present.

Manufacturer's warranty

- The period of warranty starts from the date of purchase and lasts up to 2 years for commercial use and 3 years for private use.
- Always include the completed warranty certificate when returning equipment.
- The warranty expires for appliances which have been modified without manufacturer's explicit agreement.
- Damages caused by incorrect operation or handling through non-authorized persons are not covered under the terms of warranty.
- In the event of a claim, please indicate the serial number as well as the article code number and type name with expressive description of the fault.
- This warranty covers damaged parts but no defects due to wear and tear.

In case of complaint please return the equipment in its original packaging or other suitable packaging (caution: danger of transport damage) to our service department.

Always include the completed warranty certificate when returning equipment.

Possible shipping costs arising from the transport to and from point of repair cannot be borne by us.

Outside of Germany please contact your specialist dealer in case of warranty claims. Direct warranty processing with our service department is in this case not possible.

Equipment start-up date:

Stamp and signature of the authorized electrician:

Handling procedures for return shipments (RMA) - Details for all returns !

Dear customer

we hope that you will rejoice in the ordered articles. Just in case that you are not entirely contented as an exception, please follow the procedures specified below. This enabling us to ensure a quick and smooth handling of the return shipment.

Please absolutely respect for all returns!

- Please add the available **RMA-voucher** always **completely filled out** together with an **invoice copy** to the return shipment! Do not stick it on the goods or on the packaging. **We do not accept the return shipment without these papers.**
- Not prepaid parcels **will be refused** and returned to Sender! Please always ask for the **RMA-No.** for the cheapest return.
- **Please pay attention that** the goods have to be sent back **without visible marks of use** in the **original scope of delivery and in original packing.**
- We recommend to use an **additional solid and break-proof covering box** which should be padded out with styrofoam, paper or similar. Transport damages as a result of faulty packing are for the sender's account.

Form of complaint:

1) Transport damage

- Please check the content of your parcel immediately and advise the forwarding company of a claim (parcel service/ freight forwarder)
- Do not use damaged goods!
- Ask the forwarder **for a written acknowledgement of the damages.**
- **Report the claim promptly by phone to your dealer.** He will discuss with you how to act in this case.
- If the transport box has been damaged, please use an additional covering box. Do not forget to add the **acknowledgement of the damage of the forwarding company !**

2) Faulty goods

- The implied warranty period is 2 years. Please contact your dealer in case of **faulty or wrong articles or missing accessories.** He will discuss with you the individual case and try for immediate and customer-friendly solution.
- For **economic returns** within Germany you will get an **RMA-number from the manufacturer.**
- All returns have to be in the **original packing of the goods with corresponding accessories.** Please repack the goods to avoid damages. In case of wrong delivery, please do not use this article !

3) Problems of installation and functioning

- Please **read the manual carefully first of all** and pay attention to the indicated assembly or installing instructions.
- **Your dealer should be the first contact person** because he knows his products best and also knows possible problems.
- **In case of function problems with an article,** please check at first whether there is an obvious material defect. The quality system in our factory reduces malfunctions of new appliances to almost zero.