

Infrared controlling unit 60 IR

For infrared operation

- Casing: injection moulded plastic upper and lower part
- Control buttons: two buttons for operation and cabin light one button for temperature setting
- Control: electronically via KTY-Sensor and safety temperature limiter 139°C
- Heating time shut-off: 60 minutes
- Completely premounted with connecting cable and earthing pin plug, 3-pole silicone cable for cabin lighting as well as connecting cable for the IR heating lamp.



Connection diagram

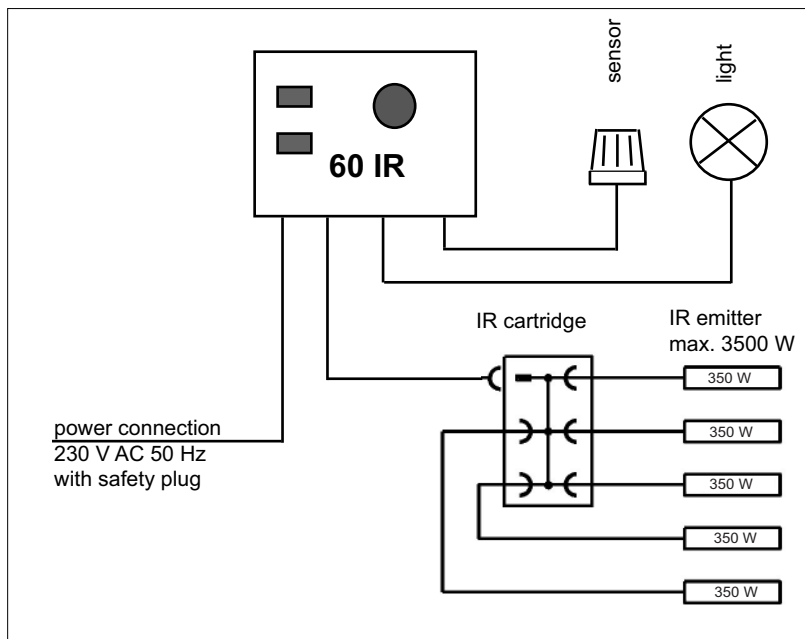

CE IPx4 AR 56 MADE IN GERMANY

Sensor mounting

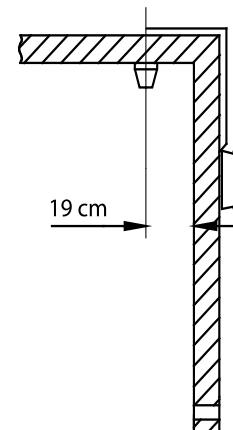

Art.-No.	Electrical connection/power	Fuse	Indicator	Control range	Dimensions H/W/D [cm]	Installation cut-out H x W	Environmental temperature	Weight without package approx.
94.3118	230 V N AC 50 Hz max. 3.5 kW	16 A	LED's for operation (green) and heating (red)	30 - 60° C	14.5/18.5/5	120x170 mm	-10°C to 40°C	1.0 kg

Subject to technical modifications