

Sauna heater Bi-O-Mat U

For hotel and commercial sauna

Rear bench heater with vaporiser

Outer shell: bright high-grade steel
 Inner shell: bright high-grade steel
 Water container: for approx. 5 litres
 Stone filling: 15 kg incl.

Stone basket with infusion bowl over full heater width.
 Infusion funnel with 1 m of silicone extension hose.
 6 metres each of silicone electrical connecting cable for the vaporiser and heating unit premounted.
 High-grade steel herb bowl for herbs and essential oils.

Connection diagram

6 - 9 kW

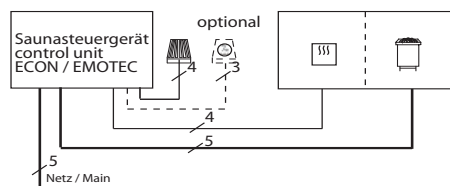

12 kW

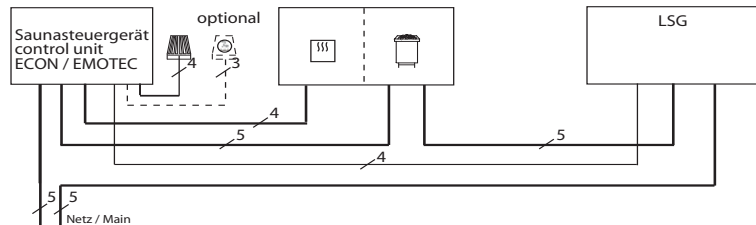

CE DE IP x4 AR 95

MADE IN GERMANY

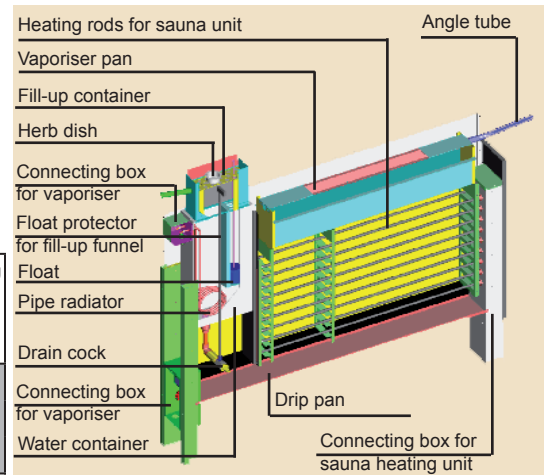

Capacity acc. DIN	Vaporiser -capacity -volume	Electrical. Connection	Fuse control unit in A	Fuse LSG in A	Connecting cable main - control unit in mm ²	Connecting cable main - LSG in mm ²	Connecting cable control unit - heater in mm ²	Connecting cable LSG - heater in mm ²	Connecting cable control unit - LSG in mm ²
6,0 kW									
7,5 kW	1,5 kW	3N AC 50 Hz 400 V	3 x 16		5 x 2,5 ²		5 x 1,5 ² & 4 x 1,5 ²		
9,0 kW	5 l								
12,0 kW				3 x 16		5 x 2,5 ²		5 x 1,5 ²	4 x 1,5 ²

All cross sections of a line are minimum diameters in mm² (Copper line)

Art.-No.	Vaporiser	Outer shell	Capacity acc. DIN	Vaporiser -capacity -volume	Installation dimensions H/W/D cm	For cabin size	Minimum dimensions of air intake and exhaust vents	Weight without stones without package	Stone filling	Power switch gear (LSG) needed	For operation with control units		
94.4890	left	high-grade steel	6,0 kW	1,5 kW	100 / 112 / 20	6 - 8 m ³	35 x 4 cm	31,5 kg	15 kg	no	ECON 45H2 EMOTEC HCS 9003 EMOTEC HCS 9003 DB/ DL/DLF EmoTouch II PB/AF/GF		
94.2587	right												
94.4891	left												
94.4894	right												
94.4892	left		7,5 kW			5 l	9 - 14 m ³	35 x 6 cm				33,0 kg	ECON 45L09 EMOTEC L09
94.4895	right												
94.1127	left												
94.2817	right												

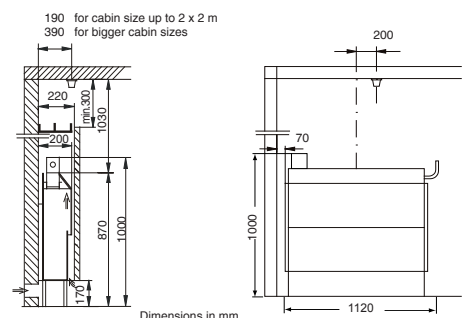

Subject to technical modifications