

Sauna heater Fin-Tec

Wall mounted heater

For family sauna

Outer shell:	anthracite pearl effect cladding of diecast aluminium
Inner shell:	high-grade steel
Rear panel:	galvanized steel plate
Stone basket:	high-grade steel
Terminal box:	galvanized steel plate
Stone filling:	15 kg incl.



Connection diagram

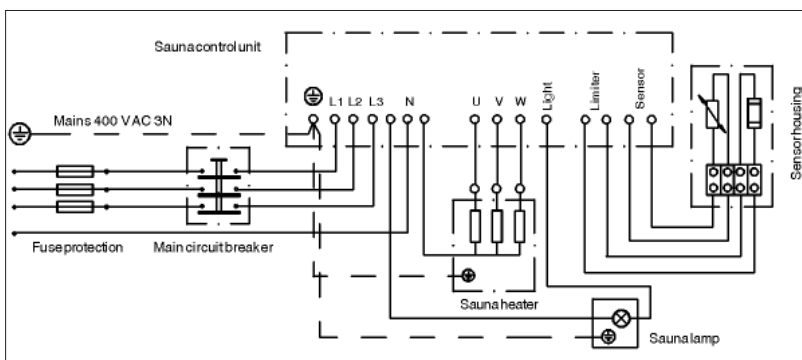

CE  IP x4 
MADE IN GERMANY

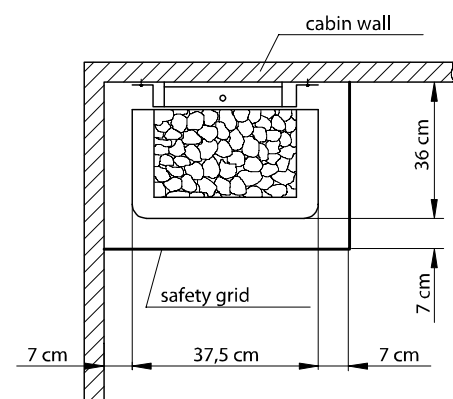
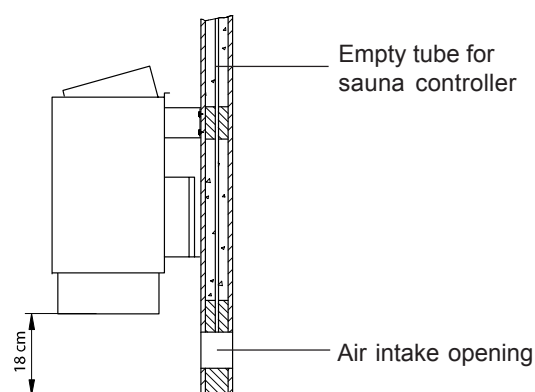

Art.-No	Outer shell	Capacity acc. DIN	Electrical connection	Installation dimensions-H/W/D cm	For cabin size	Minimum dimensions of air intake and exhaust vents	Weight without stones without package	Connecting cable control unit - heater	Power switch gear needed	For operation with control units
94.3137	anthracite pearl effect	4.5 kW	400 V 3N AC 50 Hz	78*/37.5/36	4 - 6 m³	35 x 3 cm **	11.0 kg	1 x 5G1,5	no	ECON A1 ECON A2 EMOTEC B6000 EMOTEC DC9000
94.3138	anthracite pearl effect	6.0 kW			6 - 8 m³	35 x 4 cm **				
94.3139	anthracite pearl effect	7.5 kW			7 - 10 m³	35 x 5 cm **				
94.3140	anthracite pearl effect	9.0 kW			9 - 14 m³	35 x 6 cm **	12.5 kg			

*) during 18 cm ground clearance **) or according to cabin producer's specification

Subject to technical modifications