

Supplementary vaporiser Infrasteam 200 for IR-Cabines

Housing: anthracite pearl effekt
Storage tank: high-grade steel
Water volume: approx. 2 litres

- Space-saving vaporiser.
- Electronic time control.
- Infinitely variable vaporiser control.
- Intake for vaporiser essences.
- Electrical low-water monitor incl. dry-running protection and low water buzzer.
- Plug-in connection.
- Can be retrofitted to existing IR-cabines.
- Only for operation in IR-Cabines.



Filling of the supplementary vaporiser

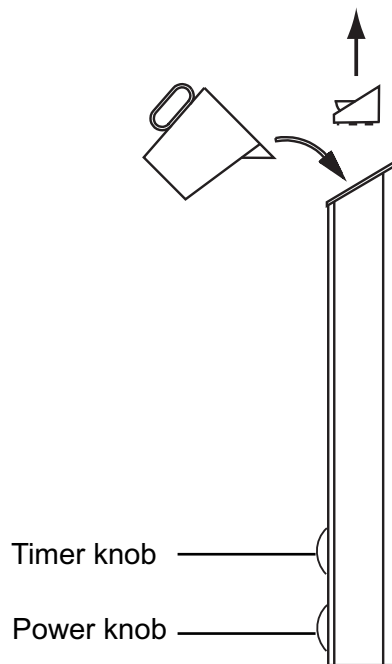

MADE IN GERMANY

Installation dimensions

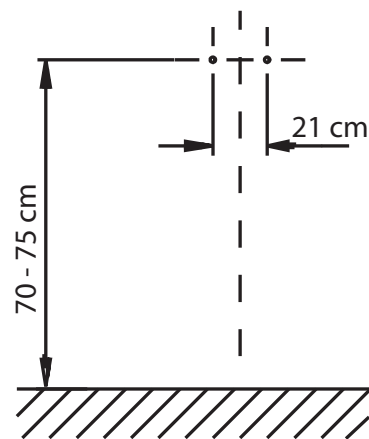

Minimum lateral distance to the cabin walls: 4 cm

Art.-No.	Outer shell	Capacity acc. DIN	Electr. Connection	Installation dimensions H/W/D cm	For cabin size	Weight without package
94.4140	Anthracite pearl effect	750 W	230 V N AC 50 Hz	52 / 22,5 / 12	up to approx. 5 m ³	5.6 kg

Subject to technical modifications