



EOS Herkules XL S50 Vapor

Sauna heater with vaporizer for commercial saunas. Floor-standing model.

Floor-standing sauna heater with built-in vaporizer for flexible sauna climate – humid sauna, herbal bath, dry sauna, etc. The unique double rock store ensures excellent heat storage capacity and allows frequent water infusions.

Your advantages:

- Durable construction. Completely made of stainless steel.
- Double rock store for excellent heat storage and powerful water infusions. With essence and herbs cup.
- With built-in vaporizer, with water level indicator.
- Slim design, only 38,5 cm depth.
- Exclusive, rich in contrast design with brushed stainless steel front and anthracite pearl effect coated side panels.
- Also available with elegant matt black finish.
- Service-friendly – rock store above heating elements.
- Made in Germany quality from EOS.

Specifications:

Outer shell:	Anthracite pearl effect powder coated sides, brushed stainless steel front.
Top:	Stainless steel
Rear wall:	Stainless steel, blank polished
Rock store:	Stainless steel, above heating elements
Terminal box:	Stainless steel, recessed in rear wall
Vaporizer:	2 kW, 5 l stainless steel tank, dry run protection, water shortage alarm
Power range:	12,0 and 15 kW
Power supply:	400 V 3N ~ 50 Hz
Dimensions (H x W x D):	75 x 75 x 38,5 cm
Stone filling:	2 x 25 kg (Sauna stones optional)
Installation:	Floor-standing



Also available with elegant matt black finish.

Connection diagram

12,0 - 15,0 kW

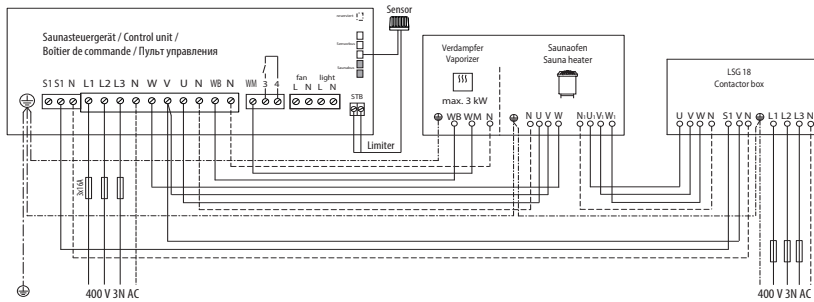

Minimum clearances

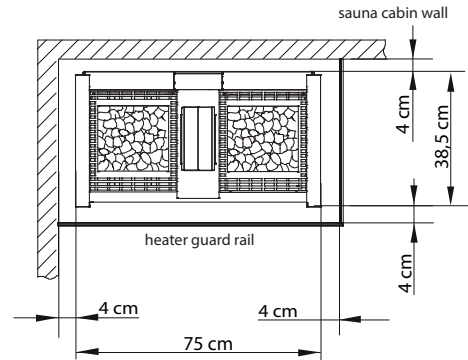

Suitable control units

Model

EOS Compact H series

EOS EmoStyle H series

EOS EmoStyle H / Hi series

EOS EmoTouch 3 series

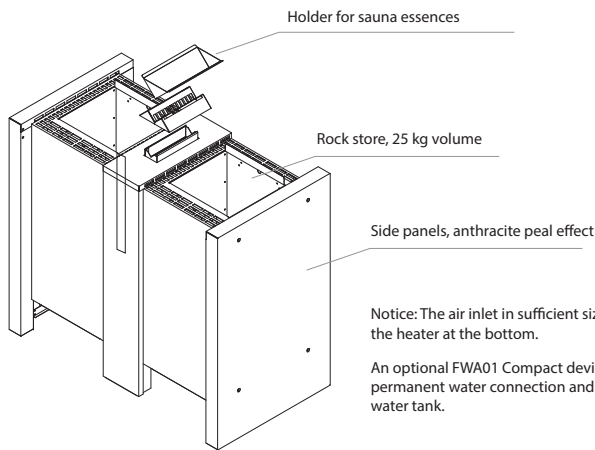

Notice: The air inlet in sufficient size must be provided behind the heater at the bottom.

An optional FWA01 Compact device may be connected for permanent water connection and automatic refilling of the water tank.

Technical specifications

Power output	Connection mains - control unit	Connection control unit - heater	Connection mains - LSG	Connection LSG - heater	Connection control unit - LSG unit
12,0 kW		5 x 1,5 mm ²			
15,0 kW	5 x 2,5 mm ²	& 4 x 1,5 mm ²	5 x 2,5 mm ²	5 x 1,5 mm ²	4 x 1,5 mm ²

All cross sections of a line are minimum diameters in mm² (copper wire).

Spare heating elements

Description	Item no.
For vaporizer, 2000 W	2000 8085
For 12,0 kW (6 x 2000 W)	2000 8085
For 15,0 kW (10 x 1500 W)	2001 4330

Item no.	Power output	Vaporizer	Electrical connection	Fuse protection control unit	Fuse protection LSG unit	Dimensions H/W/D, in cm	For sauna cabin size	Min. size air inlet and outlet	Weight without rocks	Stone filling	Power extension required
94 4330 / 94 7679*	12,0 kW	2 kW 5 l	400V 3N ~ 50 Hz	3 x 16 A	3 x 16 A	75 / 75 / 38,5	14 - 18 m ³	35 x 7 cm	49 kg	50 kg	LSG 10
94 4331 / 94 7680*	15,0 kW						18 - 25 m ³	35 x 9 cm			

*matt black finish