



Technical data sheet

## Herkules XL S50 vapor

### Sauna heater with vaporizer for commercial saunas. Floor-standing model.

Luxury class floor-standing sauna heater with built-in vaporizer for flexible sauna climate - humid sauna, herbal bath, dry sauna, etc. The unique double rock store ensures excellent heat storage capacity and allows frequent water infusions.

#### Your advantages:

- Durable construction. Completely made of stainless steel.
- Double rock store for excellent heat storage and powerful water infusions. With essence & herbs cup.
- With built-in vaporizer, with water level indicator.
- Slim design, only 38,5 cm depth.
- Exclusive, rich in contrast design with brushed stainless steel front and anthracite pearl effect coated side panels.
- Service-friendly - rock store above heating elements.
- Made in Germany quality from EOS.

#### Specifications:

Outer shell:	Anthracite pearl effect powder coated sides, brushed stainless steel front.
Top:	Stainless steel
Rear wall:	Stainless steel, blank polished
Rock store:	Stainless steel, above heating elements
Terminal box:	Stainless steel, recessed in rear wall
Vaporizer:	2 kW, 5 l stainless steel tank, dry run protection, water shortage alarm
Power range:	12,0 and 15 kW
Power supply:	400 V 3N AC 50 Hz
Dimensions (H x W x D):	75 x 75 x 38,5 cm
Stone filling:	2 x 25 kg, incl. in delivery
Installation:	Floor-standing



CE IPx4 MADE IN GERMANY

### Connection diagram

12,0 - 15,0 kW

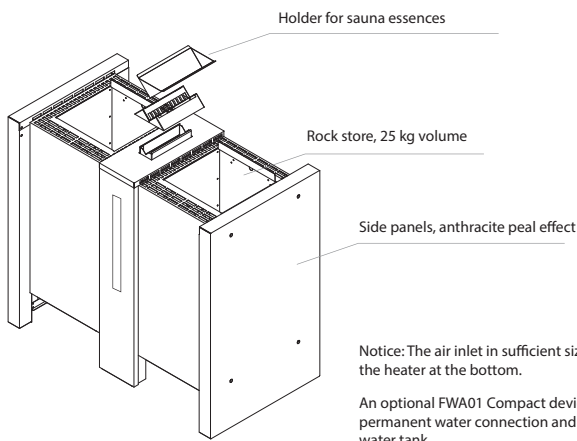
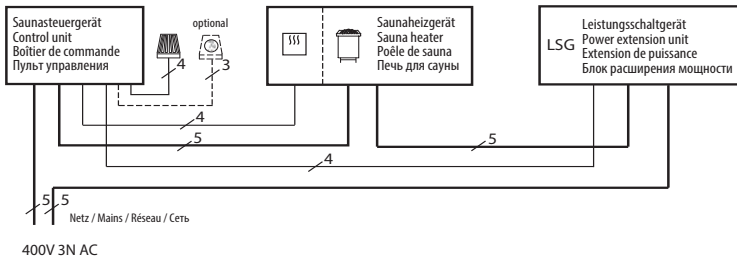

Notice: The air inlet in sufficient size must be provided behind the heater at the bottom.

An optional FWA01 Compact device may be connected for permanent water connection and automatic refilling of the water tank.

### Minimum clearances

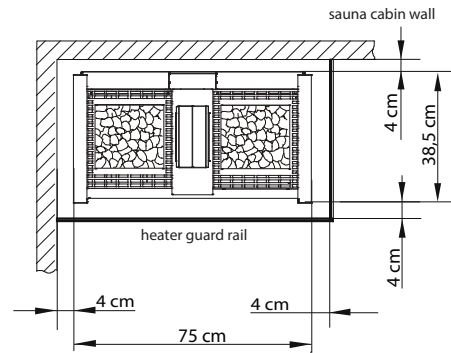

### Suitable control units

Model	Item no.
Econ H1	94.5203
Econ H2	94.5205
Econ H3	94.5550
Econ H4	94.5843
Emotec H	94.5560
EmoTouch II Plus	94.5561

### Technical specifications

Power output	Connection mains - control unit	Connection control unit - heater	Connection mains - LSG	Connection LSG - heater	Connection control unit - LSG unit
12.0 kW	5 x 2.5 mm <sup>2</sup>	5 x 1.5 mm <sup>2</sup>	5 x 2.5 mm <sup>2</sup>	5 x 1.5 mm <sup>2</sup>	4 x 1.5 mm <sup>2</sup>
15.0 kW		& 4 x 1,5 mm <sup>2</sup>			

All cross sections of a line are minimum diameters in mm<sup>2</sup> (copper wire).

### Spare heating elements

Description	Item no.
For vaporizer, 2000 W	2001.4330
For 12,0 kW (6 x 2000 W)	2000.8085
For 15,0 kW (10 x 1500 W)	2000.8085

Item no.	Power output	Vaporizer	Electrical connection	Fuse protection control unit	Fuse protection LSG unit	Dimensions H/W/D, in cm	For sauna cabin size	Min. size air inlet and outlet	Weight without rocks	Stone filling	Power extension required
94.8775	12.0 kW	2 kW 5 l	400V 3N AC 50 Hz	3 x 16 A	3 x 16 A	75 / 75 / 38,5	14 - 18 m <sup>3</sup>	35 x 7 cm	49 kg	50 kg	yes
94.8776	15.0 kW						18 - 25 m <sup>3</sup>	35 x 9 cm			