



Bi-O Invisio

Compact-size vaporizer for Invisio sauna heaters

Vaporizer for Invisio series sauna heaters. Turns the sauna heater into a Bi-O version with the possibility of flexible climate setting from hot&dry to mild and humid up to your preference. Suitable both for domestic and commercial use.

Your benefits:

- Universally suits all Invisio sauna heaters.
- Includes stainless steel steam output pipe with herbs and essence holder - steam injection at the top edge of the partition wall for optimal and quick distribution.
- The steam exit tray can be mounted at various heights.
- Right-hand side or left-hand side mounting possible.
- Double nozzle drain allows to connect the automatic water refilling device FWA01 and water drain line at one time.
- Made in Germany quality by EOS

Specifications:

Water tank:	High-grade stainless steel, approx. 5 l, front side access to heating elements.
Safety:	Integrated dry-run protection with acoustic low water signal
Water refilling:	manual, automatic refilling optionally available with the FWA01 device.
Drain:	Integrated, double nozzle drain.
Dimensions HxWxD:	530 x 200 x 360 mm
Power output:	2000 W and 3000 W
Power supply:	230 V 1N AC 50 Hz
Installation:	Side-mounting on Invisio heater. Left or right hand side installation.
Compatible heaters:	Invisio-Mini, Invisio-Midi, Invisio XL



Installation example on Invisio-Midi heater
Note: heater not included in delivery

CE IPx4 MADE IN GERMANY 

Connection diagram

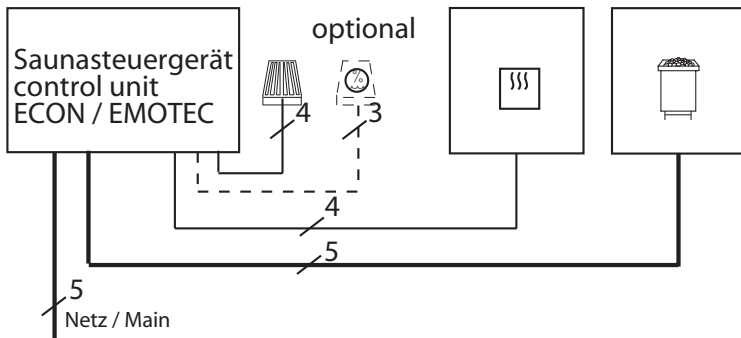

Assembly

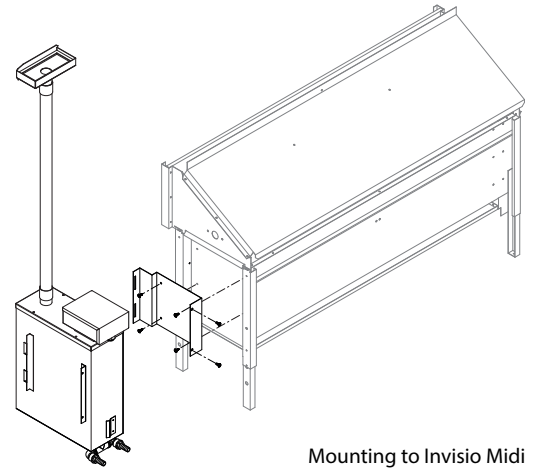

Mounting to Invisio Midi

Connection diagram

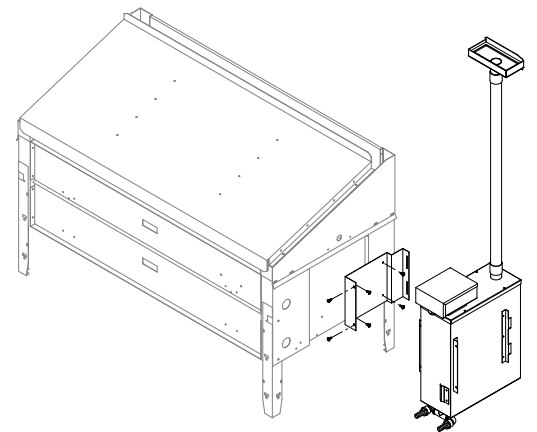
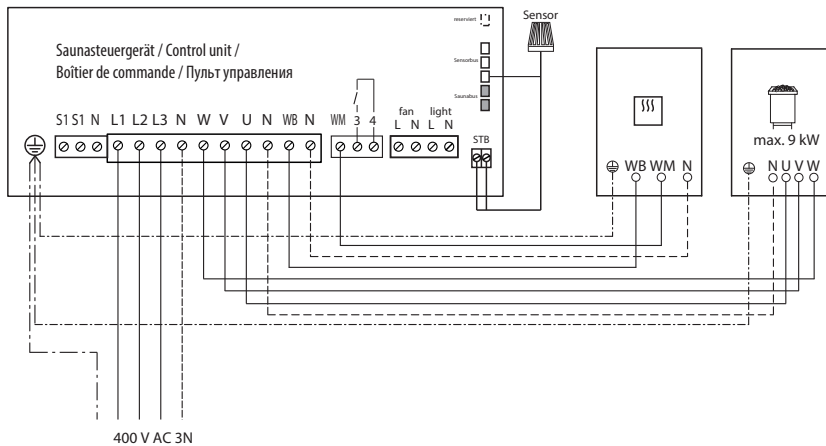

Mounting to Invisio XL

Art. No.	Electr. connection	Cable connection	Power rating	Dimensions H x W x D, cm	Tank volume	Steam pressure	Control
94.6293 94.6294	230 V N AC 50Hz	4 x 1.5 mm ²	2.000 W 3.000 W	53 x 20 x 36 (without steam pipe)	max. 10 l	0 bar pressureless	All „H“ series sauna control units

All information on cable cross-sections are minimum cross-sections in mm² copper line.